

# T and TV Series Expansion Tanks For Domestic Heating Systems

## DESCRIPTION

---

Cash Acme's T and TV Series Expansion Tanks are designed for heating systems applications. They feature a robust construction, with a welded seam for greater durability.

The Cash Acme TV Series Floor Standing Expansion Tanks are for use in larger heating systems to absorb the increased hot water volume due to expansion.

**SIZES:**

T-15 @ 2.0 gal  
T-30 @ 5.0 gal  
T-60 @ 7.0 gal  
T-90 @ 15.0 gal

**SIZES:**

TV-30 @ 15.0 gal  
TV-40 @ 20.0 gal  
TV-60 @ 36.0 gal  
TV-90 @ 52.0 gal  
TV-110 @ 86.0 gal  
TV-160 @ 96.0 gal

## FEATURES AND BENEFITS

---

Welded Construction:

*Ensures long and reliable service.*

Heavy duty Butyl diaphragm and epoxy paint finish:

*Long lasting and resistant to external elements.*

Provides place for expanding water:

*Eliminates damage to the boiler and piping.*

Gives water a place to flow when thermal expansion occurs:

*Eliminates costly and serious effects such as noisy water hammering pipes and damaged connections.*

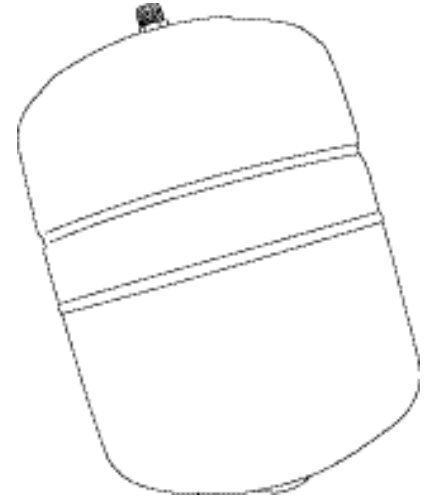

**T Expansion Tank**



**TV Expansion Tank**

# T and TV Series Expansion Tanks For Domestic Heating Systems

## TYPICAL INSTALLATION

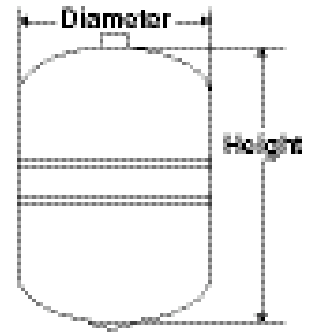
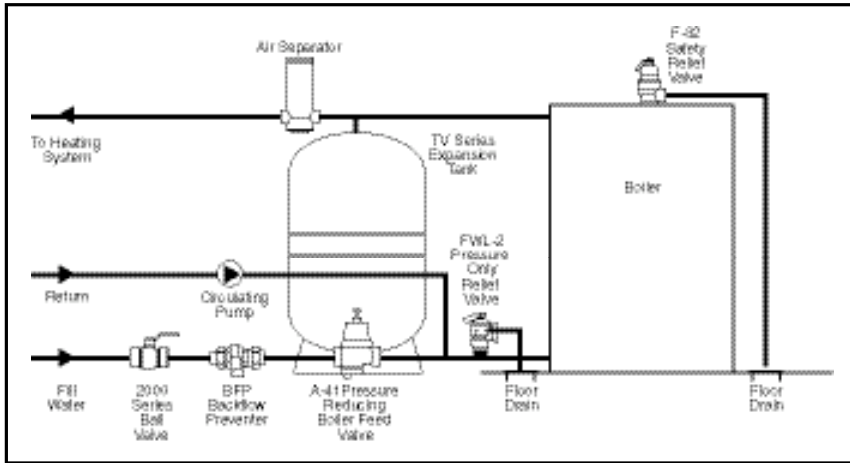

T Expansion Tank

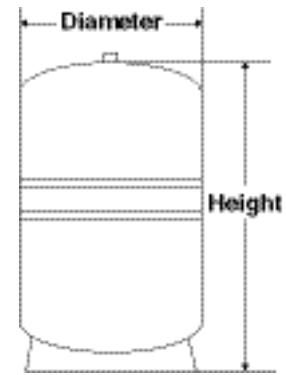

TV Expansion Tank

See dimensions for both tanks on the chart at left.

## SPECIFICATION DATA

In-Line Models	Capacity (gal)	Acceptance Volume (gal)	Conn. NPTM	Max. Work. Pressure (psig)	Factory Precharge	Diameter	Height	Weight
T-15	2.0	1.50	1/2"	100	12	8.38"	12.50"	5.0
T-30	5.0	3.75	1/2"	100	12	11.38"	14.75"	8.0
T-60	7.0	4.60	1/2"	100	12	11.38"	21.13"	11.0
T-90	15.0	10.50	1/2"	100	12	15.38"	15.75"	22.0
<b>Stand Models</b>								
TV-30	15.0	10.5	1/2"	100	12	15.38"	24.75"	25.0
TV-40	20.0	13.5	1/2"	100	12	15.38"	32.75"	32.0
TV-60	36.0	21.0	1/2"	100	12	20.0"	32.63"	45.0
TV-90	52.0	34.0	1/2"	100	12	23.38"	38.63"	80.0
TV-110	86.0	61.0	1/2"	100	12	23.38"	32.63"	99.0
TV-160	96.0	64.0	1/2"	100	12	23.38"	59.00"	99.0

## T-TV SERIES DIAPHRAGM EXPANSION TANK SELECTION

Average System Temperature (°F)

System Content	100°	110°	120°	130°	140°	150°	160°	170°	180°	190°	200°	210°	220°	230°	240°
25 gal.	T15	T15	T15	T15	T15	T15	T15	T15	T15	T15	T30	T30	T30	T30	T30
50 gal.	T15	T15	T15	T15	T15	T30	T30	T30	T30	T30	T30	T30	T60	T60	T60
75 gal.	T15	T15	T15	T30	T30	T30	T30	T30	T60	T60	T60	T90	T90	T90	T90
100 gal.	T15	T15	T30	T30	T30	T30	T60	T60	T90	T90	T90	T90	T90	T90	T90
200 gal.	T30	T30	T30	T70	T70	T70	T90	T90	TV40	TV40	TV40	TV40	TV60	TV60	TV60
300 gal.	T30	T60	T90	T90	T90	T90	TV40	TV40	TV60	TV60	TV60	TV90	TV90	TV90	TV90
400 gal.	T60	T90	T90	T90	TV40	TV40	TV40	TV60	TV90	TV90	TV90	TV90	TV110	TV110	TV110
500 gal.	T90	T90	T90	TV40	TV40	TV60	TV60	TV90	TV90	TV90	TV110	TV110	TV110	TV110	TV110
600 gal.	T90	T90	TV40	TV40	TV60	TV60	TV90	TV90	TV110	TV110	TV110	TV110	TV110	TV160	TV160
700 gal.	T90	T90	TV40	TV60	TV60	TV60	TV90	TV110	TV110	TV110	TV110	TV160	TV160		
800 gal.	T90	TV40	TV40	TV60	TV90	TV90	TV110	TV110	TV110	TV110	TV160	TV160			
900 gal.	T90	TV40	TV60	TV90	TV90	TV90	TV110	TV110	TV110	TV160	TV160				
1000 gal.	TV40	TV40	TV60	TV90	TV90	TV110	TV110	TV110	TV160	TV160					

### Materials:

Diaphragm .....Butyl  
 Finish .....Epoxy Paint  
 Shell .....Steel